

# The polishing process of advanced ceramic balls using a novel eccentric lapping machine

J. Kang<sup>a,\*</sup>, M. Hadfield<sup>b</sup>

<sup>a</sup>*School of Engineering and Design, Brunel University, UK*

<sup>b</sup>*School of Design, Engineering & Computing, Bournemouth University, UK*

**Abstract:** The finishing process of advanced ceramic balls can be divided into two steps. The first step is lapping in which most of the stock from the ball is removed at a higher material removal rate. The second step is polishing in which the required ball surface roughness, roundness, dimensional and geometric accuracy are achieved. In polishing, the abrasive particle size is  $\leq 1 \mu\text{m}$ , and the load and speed are lower than lapping.

A novel eccentric lapping machine is used for polishing HIPed (Hot Isostatically Pressed) silicon nitride balls. In the initial polishing stage, the polishing load is demonstrated most influential in the reduction of surface roughness value  $R_a$ . However, in the later polishing stages, the erosive process played a major role in the further reduction of  $R_a$ , although the high roughness peaks cannot be removed by erosive process alone. Experimental results also show that in order to achieve desired surface roughness value, the initial surface quality of the upper plate should be reasonably high, and deep scratches should be avoided to leave on the ball surface in previous lapping process.

The best polishing results achieved were surface roughness values of  $R_a$  of  $0.003 \mu\text{m}$  and rms ( $R_q$ ) of  $0.004 \mu\text{m}$ , ball roundness of  $0.08\text{--}0.09 \mu\text{m}$ . This proves the novel eccentric lapping machine is suitable for polishing advanced ceramic balls as well.

**Keywords:** Abrasion, Erosion, Ceramic Balls, Polishing, Finishing, Eccentric Lapping, Taguchi Methods, Silicon Nitride, Hybrid Bearings

---

\* Corresponding author: School of Engineering and Design, Brunel University,  
Tower A, Uxbridge Campus, Uxbridge, Middlesex, UB8 3PH, UK  
Tel. +44 (0)1895 266330  
Fax. +44 (0)1895 2697639  
E-mail: Jinsheng.Kang@Brunel.ac.uk

## NOTATION

$R_a$	arithmetical deviation of the assessed profile
$rms$	root mean square deviation of the assessed profile, also called $R_q$
$R_z$	ten point height of the assessed profile
$R_{ku}$	kurtosis of the assessed profile
$PV$	maximum peak-to-valley height of the assessed profile
$GTSS$	grand total sum of squares of Signal-to-Noise ratio
$n_{Ai}$	number of tests conducted at level $i$ of parameter A
$S/N$	Signal-to-Noise ratio
$S/N_{STB}$	Signal-to-Noise ratio (smaller-the-better)
$\overline{S/N}$	overall mean of Signal-to-Noise ratios
$\overline{S/N}_{Ai}$	the level average S/N of parameter A at level $i$
$SS_A$	the sum of the squares of the S/N variation induced by parameter A around overall mean.
$SS_B$	the sum of the squares of the S/N variation induced by parameter B around overall mean.
$SS_C$	the sum of the squares of the S/N variation induced by parameter C around overall mean.
$SS_{mean}$	the sum of the squares due to overall mean of S/N
$SS_{variation}$	the sum of the squares due to variation around overall mean of S/N
$y_i$	the individually measured response value at measurement $i$

## 1 INTRODUCTION

Rolling bearing technology reflects the advances in materials, manufacturing and tribology. Current demands on rolling bearings are leading to developments aimed at running them at high speeds, hostile environments, increased stresses and thermal stresses, and restricted lubrication. Advanced ceramic balls have the optimum combination of properties to meet such demands as rolling elements in hybrid bearings (with steel inner and outer rings) and all-ceramic bearings [1]. Unfortunately, the high manufacturing cost of ceramic balls, especially in the finishing process (currently the finishing process

constitutes half of the total cost of manufacturing), hinders their widespread application.

The finishing process of advanced ceramic balls can be divided into two steps. The first step is lapping in which most of the stock from the ball is removed at higher material removal rate. The second step in the finishing process is polishing, in which the ball surface roughness, roundness, dimensional and geometric accuracy are achieved. The difference between lapping and polishing, as defined by Marinescu et al [2], is that the abrasive particle size for lapping is normally 1~30  $\mu\text{m}$ , while for polishing, the abrasive particle size is  $\leq 1 \mu\text{m}$ . The size of the chips (stock removal) for lapping is in the range of  $10^{-3}\sim 10^{-7}$  m, while for polishing, in the range of  $10^{-7}\sim 10^{-9}$  m. A damaged layer and micro-cracks were very often induced by lapping but not by polishing. The applied load and speed for polishing were both usually lower than for lapping.

Some research has been conducted trying to accelerate the finishing process of advanced ceramic balls, for example, Magnetic Fluid Grinding (MFG), also called Magnetic Float Grinding (Polishing). In 1996 Umehara and Kato [3] concluded from the results in the last seven years and summarized that: the material removal rate and surface roughness obtained from MFG method are quite satisfactory, but the sphericity of the balls has not achieved to less than  $0.1 \mu\text{m}$  which is required by high precision ball bearings. They reported the best surface quality achieved by MFG was surface roughness value  $R_a < 0.01 \mu\text{m}$  and ball roundness  $0.14 \mu\text{m}$  [3]. Later research on MFG by Jiang and Komanduri achieved a surface roughness value  $R_a = 0.004 \mu\text{m}$  and ball roundness  $0.25 \mu\text{m}$  [4]. Childs et al. both studied magnetic and non-magnetic fluid grinding of ceramic balls. Their magnetic fluid grinding achieved a surface roughness value  $R_a$  of  $0.025 \mu\text{m}$  and a ball roundness error of  $\pm 1 \mu\text{m}$  [5], and their non-magnetic fluid grinding achieved a ball roundness error of  $3\mu\text{m}$  [6]. The fundamental mechanisms of material removal in lapping and polishing processes were reviewed in full by Evans et al. [7].

A novel eccentric lapping machine was designed and prototyped in-house by the authors [8] (Fig 1). The major difference between this eccentric lapping machine and conventional concentric lapping machine is that there is an offset between the rotating axis and the centre of circular V-groove on the lower plate, and the upper plate is flat and stationary (Fig 2). Because of this eccentricity, the kinematics and dynamics of eccentric lapping is much more complicated than conventional concentric lapping. There is an acceleration and deceleration on ball circulation speed during each revolution of lower plate, also the ball spin angle and ball spin angular speed are changing constantly. It was anticipated at certain points during each revolution there are microslips between the balls and the

plates. Two kinds of HIPed (Hot Isostatically Pressed) silicon nitride ball blanks were lapped on this machine. A lapping rate of 68  $\mu\text{m}/\text{hour}$  was achieved, which is 15 times higher than conventional concentric lapping (normally 3~4  $\mu\text{m}/\text{hour}$ ). The cost saving of this eccentric lapping machine is obvious during the first step of finishing – lapping (assuming the finishing time is proportional to the cost). It is unclear if this eccentric lapping machine is still cost saving in the second step of finishing – polishing, since individual polishing processes are well controlled within individual enterprises and no comparison has been made. The major concern of the current study is to investigate the performance of this eccentric lapping machine in the polishing stage, the achievable surface roughness and ball roundness values, and all the influencing factors that affect the surface quality in the polishing stage.

## 2. EXPERIMENTAL SET-UP

All the experimental investigations were carried out on this novel eccentric lapping machine (Fig 1). Full details on this machine can be found on an earlier publication [8]. A pair of mild steel lapping plate was used for polishing test. A summary of polishing materials is listed in Table 1. Polishing tests were conducted on two types of HIPed (Hot Isostatically Pressed) silicon nitride balls, and their characteristics are shown in Table 2.

Before and after each polishing test, balls and lapping plates were cleaned using an ultrasonic bath, each ball diameter was measured to  $\pm 1 \mu\text{m}$ , and microscope observations, ball roundness and surface roughness measurements were conducted. Each polishing test lasted 24 hours. The polishing fluid was pumped at intervals, through a tube to the centre of upper plate by means of the ProMinent gamma/4 diaphragm-type metering pump at pre-set stroke. The polishing fluid was a mixture of diamond paste and lubricating fluid at a concentration of 1g:100ml. This was mixed and maintained in equal concentrations by a magnetic stirrer. The amount of polishing fluid applied was controlled by the pre-set stroke number/min of the pump plus a timer. The application time was for 5 minutes every 4 hours, set by the timer's ON and OFF periods. The pump and magnetic stirrer activated simultaneously with the timer's ON period. Thus, every 4 hours, an amount of 5ml of polishing fluid mixture was added to the lapping plates through the pipe at the centre of top plate.

### 3 EFFECTS OF POLISHING LOAD, SPEED AND DIAMOND PARTICLE SIZE ON SURFACE ROUGHNESS $R_a$ ASSESSED BY TAGUCHI METHODS

The Taguchi Methods developed by Dr Genichi Taguchi are methodologies for design of experiments, which use a set of standard orthogonal arrays to run the tests and a series of algorithms to analyse the test results. More precise information about the influences of experimental parameters can be extracted from fewer tests by Taguchi Methods. A detailed explanation on the Taguchi Methods can be found in an earlier publication investigating the influences of different parameters on the material removal rate during the lapping process on this eccentric lapping machine [9]. In the current study on polishing tests, a standard two-level, three-parameter L4 orthogonal array was chosen, as shown in Table 3. The three parameters to be investigated were polishing load, polishing speed and diamond particle size, and their two level values are listed in Table 4. Because the smallest surface roughness value  $R_a$  is the target (objective function), the smaller-the-better signal-to-noise ration  $S/N_{STB}$  was chosen for analysis. The basic formulae and notation used in this study can be found in reference [10].

$$S/N_{STB} = -10 \log \left[ \frac{1}{n} \sum_{i=1}^n y_i^2 \right] \quad (1)$$

Ceramic balls being polished in this investigation are Type 1 balls as procured from the manufacturer A with an initial surface roughness value  $R_a$  0.202  $\mu\text{m}$ , and their characteristics are listed in Table 2. Each polishing test lasted 24 hours. After 24 hours polishing, the ball diameter reductions were all the same in four tests, a reduction of 2  $\mu\text{m}$  from 13.255 to 13.253. The ball surface roughness values for each test were measured by a Talysurf 2D surface profiler, with a 2CR-ISO filter and cut-off 0.8mm. Table 5 shows the results of four tests measured from 10 samples, the average value and the  $S/N_{STB}$  value of each test, as well as the STDEVP – standard deviation for entire population of each test.

From Table 5 we can see that Test 1 obtained the worst results with highest average  $R_a$  value of 0.0485  $\mu\text{m}$ , highest STDEVP value of 0.0055  $\mu\text{m}$  which means the batch data are more scattered, and lowest Signal-to-Noise ratio of 26.24 dB. This came with all the three parameters set at low level, which are lower polishing speed, lower polishing load and smaller diamond particle size. Test 2 acquired the smallest average  $R_a$  value of 0.0300  $\mu\text{m}$  and the best Signal-to-Noise ratio of 30.41, but the batch data were a bit scattered with a STDEVP value of 0.0035  $\mu\text{m}$ . This was achieved when the polishing speed was lower, the polishing load was higher and diamond particle size was bigger. Test 3 achieved less batch data scatter, but not desired  $R_a$  value and S/N ratio when polishing speed was high, polishing

load was low and diamond particle size was bigger. Test 4 obtained reasonably satisfactory  $R_a$  value, STDEVP value and S/N ratio as well, whilst the polishing speed and load were higher, and diamond particle size was small.

Table 6 shows the results of level average response analysis in terms of surface roughness value  $R_a$  and in terms of signal-to-noise ratio  $S/N_{STB}$ . The level average response analysis is based on averaging the experimental results achieved at each level for each parameter. Because of the symmetric property of Taguchi standard orthogonal array, when performing level average analysis for one level of one parameter, all the influences from different levels of other parameters will be counterbalanced. Thus the effect of one parameter at one level on the experimental results can be separated from other parameters. From Table 6 we can see that the polishing speed of 93.75 rpm gave better results in level average  $R_a$  value than at 20.83 rpm, but the difference was very small: only 8%. This indicates that the surface roughness  $R_a$  value will not be improved by lowering the polishing speed. A change of polishing speed within this range has less effect. Much better average surface roughness  $R_a$  value was achieved by a polishing load at 8.82 N/ball than at 4.58 N/ball: the  $R_a$  value decreased by 34%. This implies that the polishing load has significant influence on the  $R_a$  value. The difference between using 0.25  $\mu\text{m}$  and 1  $\mu\text{m}$  diamond particle sizes was also very small: 8%, although the 1  $\mu\text{m}$  diamond particle size proved slightly better. This means 1  $\mu\text{m}$  diamond particle size is suitable in the initial polishing stage for quickly reducing the  $R_a$  value. But in the later polishing stage, 0.25  $\mu\text{m}$  diamond particle size was found to be better in achieving final finishing surface roughness in some other independent polishing tests. The level average response value of  $S/N_{STB}$  confirmed that the polishing load at 8.82 N/ball has much better result on signal-to-noise ratio (30.39 dB) than polishing load at 4.58 N/ball (26.84 dB). For the two different levels of polishing speed and diamond particle size, the level average response values of  $S/N_{STB}$  have little differences.

The analysis of variance (ANOVA) uses S/N ratio to calculate the relative contribution of each parameter to the overall response, and expressed as a percentage. The overall mean from which all the variation (standard deviation) is calculated is given by

$$\overline{S/N} = \frac{1}{n} \sum_{i=1}^n S/N_i \quad (2)$$

In this study,

$$\overline{S/N}_{STB} = \frac{1}{4} \sum_{i=1}^4 (S/N_{STB})_i = \frac{1}{4} (26.24 + 30.41 + 27.44 + 30.37) = 28.61$$

The grand total sum of squares GTSS is given by

$$GTSS = \sum_{i=1}^n (S/N_i)^2 \quad (3)$$

In this case,

$$GTSS = \sum_{i=1}^4 (S/N_{STB})_i^2 = (26.24)^2 + (30.41)^2 + (27.44)^2 + (30.37)^2 = 3288.28$$

The GTSS can be decomposed into two parts, the sum of the squares due to the overall mean and the sum of the squares due to variation around the overall mean:

$$GTSS = SS_{mean} + SS_{variation} \quad (4)$$

The sum of the squares due to the overall mean:

$$SS_{mean} = n \times (\overline{S/N})^2 \quad (5)$$

Where n is the number of total test runs, and in this case,

$$SS_{mean} = 4 \times (\overline{S/N}_{STB})^2 = 4 \times (28.61)^2 = 3274.95$$

The sum of the squares due to variation around the overall mean:

$$SS_{variation} = \sum_{i=1}^n (S/N_i - \overline{S/N})^2 \quad (6)$$

In this study,

$$SS_{variation} = \sum_{i=1}^4 ((S/N_{STB})_i - \overline{S/N}_{STB})^2 = (26.24 - 28.61)^2 + (30.41 - 28.61)^2 + (27.44 - 28.61)^2 + (30.37 - 28.61)^2 = 13.33$$

The  $SS_{variation}$  can be further decomposed into the sums of the squares of the variation induced by individual parameter effects around the overall mean. The level average S/N minus overall mean S/N is the variation caused by that parameter at that level.

For parameter A, the sum of the squares due to variation around the overall mean is

$$SS_A = n_{A1} \times (\overline{S/N}_{A1} - \overline{S/N})^2 + n_{A2} \times (\overline{S/N}_{A2} - \overline{S/N})^2 \quad (7)$$

Where  $n_{Ai}$  is number of tests conducted at level i of parameter A, and  $\overline{S/N}_{Ai}$  is the level average S/N of parameter A at level i

In this case,

$$SS_A = 2 \times (28.32 - 28.61)^2 + 2 \times (28.90 - 28.61)^2 = 0.34(\text{dB})^2$$

Similarly,

$$SS_B = 2 \times (26.84 - 28.61)^2 + 2 \times (30.39 - 28.61)^2 = 12.60 (\text{dB})^2$$

$$SS_C = 2 \times (28.30 - 28.61)^2 + 2 \times (28.93 - 28.61)^2 = 0.39 (\text{dB})^2$$

The percentage contribution of each parameter is found:

$$\text{Percentage contribution of Parameter } j = (SS_{\text{parameter } j} / SS_{\text{variation}}) \quad (8)$$

In this study (j=A, B, C),

$$\text{Parameter A, Polishing Speed: } (0.34/13.33) \times 100 = 2.51\%$$

$$\text{Parameter B, Polishing Load: } (12.60/13.33) \times 100 = 94.56\%$$

$$\text{Parameter C, Diamond Particle Size: } (0.39/13.33) \times 100 = 2.93\%$$

The analysis of variance shows that the polishing load is the most influential parameter in the reduction of surface roughness value  $R_a$ . The influences of polishing speed and diamond particle size is very small.

The polishing load parameter was most effective during this investigation, and it counted for 95% of the total contribution. This is due to the fact that these polishing test samples were procured from the manufacturer as ball blanks with a surface roughness value  $R_a$  0.202  $\mu\text{m}$ . Thus the polishing process investigated here by Taguchi Methods can only represent circumstance of initial polishing stage with higher initial surface roughness value. It implies that in the initial polishing stage, the higher polishing load can quickly reduce the surface roughness value whilst the polishing speed and diamond particle size have little influences. But in the later polishing stage in obtaining final finishing surface roughness, the 0.25  $\mu\text{m}$  diamond particles did constantly achieved much better polishing results than 1  $\mu\text{m}$  diamond particles.

#### 4 EFFECTS OF EROSIIVE PROCESS IN POLISHING

The significance of erosive process in polishing was found incidentally. The initial intention was to place one or two smaller diameter balls between the polished balls in order to eliminate the gap and to avoid the clash between the balls (Fig 3). It was found that after the polishing process the surface roughness of those smaller balls was improved significantly, and even the ball diameter was reduced,



although those smaller balls did not touch the top plate and there was no polishing load on them. They were mainly polished by erosive process.

The erosive process occurs when discrete solid particles strike a surface. In erosion, the extent of wear depends instead on the number and mass of individual particles striking the surface, and on their impact velocity [11]. In our case, the forces causing the impact velocity of a diamond particle would be mainly the polishing fluid drag force, the impact forces from neighbouring diamond particles, ceramic ball and lower plate, the centrifugal force. The erosive process involves both plastic deformation and brittle fracture. More detailed description about erosive process can be found in reference [11].

In order to systematically assess the effects of erosive process in the polishing of advanced ceramic balls, two set of comparison tests were conducted. The first set of comparison tests were on Type 1 balls after a normal initial polishing process with an average  $R_a$  value around  $0.04 \mu\text{m}$ . The first batch was polished under gap polishing condition. Ten Type 1 balls were gap polished without any polishing load, using five another type of ceramic balls with slightly bigger diameter to bear the entire polishing load. The second batch was polished under normal polishing condition, in which fifteen Type 1 balls with the same diameter were polished under an average polishing load of  $0.8 \text{ kgf/ball}$  ( $7.8\text{N/ball}$ ). They were both polished for 3 days (72 hours) with  $0.25 \mu\text{m}$  diamond paste fluid mixture as described in Section 2. The second set of comparison tests were on Type 2 balls after a normal initial polishing process with an average  $R_a$  value around  $0.03 \mu\text{m}$ . The first batch was polished under gap polishing condition and the second batch was polished under normal polishing condition, exactly the same setting up as Type 1 balls described before. After polishing, surface topography of the two sets was measured using a Zygo New View 3D surface structure analyser. Fig. 4 shows the typical surface topography comparison of Type 1 balls gap polished with normal polished, and Fig. 5 is the typical comparison for Type 2 balls.

There are some characteristics in common from the two sets of comparisons. There were no significant differences between gap polished and normal polished balls regarding to the surface roughness value  $R_a$  (arithmetical mean) and the surface roughness value rms (root mean square, also called  $R_q$ ), although the normal polished balls from Type 1 and Type 2 have both achieved slightly better results than gap polished balls. For Type 1 balls, the  $R_a$  is  $0.010 \mu\text{m}$  and rms is  $0.015 \mu\text{m}$  for gap polished whilst the  $R_a$  is  $0.008 \mu\text{m}$  and rms is  $0.010 \mu\text{m}$  for normal polished. For Type 2 balls, the  $R_a$  is  $0.006 \mu\text{m}$  and rms is  $0.008 \mu\text{m}$  for gap polished whilst the  $R_a$  is  $0.004 \mu\text{m}$  and rms is  $0.005 \mu\text{m}$  for normal

polished. This indicates that the erosive process did make a major contribution to the reduction of surface roughness value  $R_a$  and rms in the polishing process of advanced ceramic balls.

However, for the surface roughness value PV (maximum peak-to-valley height), the gap polished balls both from Type 1 and Type 2 only achieved values which are more than two times higher than normal polished balls. This is illustrated by the PV values of  $0.527 \mu\text{m}$  against  $0.220 \mu\text{m}$  for Type 1 balls, and the PV values of  $0.352 \mu\text{m}$  against  $0.144 \mu\text{m}$  for Type 2 balls. This phenomenon is further demonstrated by the surface roughness value  $R_z$  (Ten point height, the mean distance between the five highest peaks and five lowest valleys within the sample length). For Type 1 balls, the  $R_z$  value is  $0.324 \mu\text{m}$  for gap polished and  $0.168 \mu\text{m}$  for normal polished. The  $R_z$  value for gap polished is almost 2 times higher than normal polished. For Type 2 balls, the  $R_z$  value is  $0.098 \mu\text{m}$  for gap polished and  $0.057 \mu\text{m}$  for normal polished. The  $R_z$  value for gap polished is 1.7 times higher than normal polished.

This is further in consistent with the much higher surface roughness  $R_{ku}$  (kurtosis) values of gap polished Type 1 and Type 2 balls, which are both 4 times higher than normal polished. For Type 1 balls, the  $R_{ku}$  (kurtosis) value is 29.866 for gap polished and 7.155 for normal polished. For Type 2 balls, the  $R_{ku}$  (kurtosis) value is 41.652 for gap polished and 10.002 for normal polished. The much higher  $R_{ku}$  (kurtosis) value means that gap polished balls have a spiky surface, and the high roughness peaks can not be removed by erosive process alone. The lower PV values,  $R_z$  values and  $R_{ku}$  values of normal polished balls implies the effectiveness of three-body-loose-abrasive process in removing high roughness peaks. From this it can be inferred to a larger extent that the three-body-loose-abrasive process under normal polishing condition with polishing load will be responsible for the improvement of ball roundness value as well.

## 5 OTHER INFLUENCING FACTORS IN POLISHING

Another most influential factor in the polishing stage is the condition of the top plate. The best polishing results were achieved when the upper plate lapping area was mirror-shining (a mirror-like surface was generated due to the self-polishing effect). In an attempt to explore the self-polishing effect of the top plate, a rough turned upper plate was used for polishing under a 14.7 N/ball polishing load. Fig. 6 shows waviness in the appearance of the upper plate lapping area. This waviness may be due to the initial lapping surface having been too rough (see centre of the plate), or to the polishing load having been too high. Under this circumstance, the desired surface roughness values of the polished

balls could not be achieved. This suggests that the initial surface quality of the upper plate should be reasonably high.

The deep scratches left on the ball surface by diamond particle ploughing during the previous lapping process (see “Intensity Map” and Oblique Plot” in Fig.4) could be difficult to remove during the polishing process, when stock removal is very small. This suggests that in order to obtain better surface quality, the diamond particle size should be reduced gradually, to avoid leaving any deep scratches on the lapped ball surface.

Other factors which could influence the polishing quality are the condition of the V-groove in the lower plate and contamination of the polishing fluid by large diamond particles previously left in the pipeline, etc..

## 6 POLISHING RESULTS

The best polishing results so far achieved for Type 2 balls are a ball roundness of 0.08~0.09  $\mu\text{m}$  which is above the grade 5 and close to the grade 3 specification for precision bearing balls. Fig. 7 is the ball roundness measurement of Type 2 balls after lapping before polishing by a MWA 160B roundness machine, and the roundness value was 0.2091  $\mu\text{m}$ . Fig. 8 is the ball roundness measurement of Type 2 balls after polishing by a Taylor-Hobson Talyrond 73 roundness profiler, and the roundness value is 0.092  $\mu\text{m}$ . Another previous measurement had achieved the roundness value of 0.087  $\mu\text{m}$  [8]. The best polished ball surface roughness value of Type 2 balls achieved so far are a  $R_a$  value of 0.003 $\mu\text{m}$ , and a rms ( $R_q$ ) value of 0.004  $\mu\text{m}$  which is above the grade 3 specification for precision bearing balls. Fig. 9 shows two surface topography measurements for Type 2 balls after polishing using a Zygo New View 3D surface structure analyser. Although the measured surface roughness  $R_a$  value from Fig. 9 (a) is 0.004  $\mu\text{m}$ , which is higher than the measurement from Fig. 9 (b), the measured surface roughness values PV,  $R_z$  and  $R_{ku}$  are all much lower from Fig. 9 (a).

## 7 CONCLUSIONS

Two types of advanced ceramic balls were polished by a novel eccentric lapping machine. From a limited number of experimental investigations, the following preliminary conclusion can be drawn:

- (1) In the initial polishing stage, the polishing load is the predominant factor. Higher polishing load can result in quick reduction of surface roughness value  $R_a$ . At the initial polishing stage, the polishing speed and diamond particle size are not important.
- (2) In the later polishing stage, the erosive process (without polishing load) played a major role in the further reduction of surface roughness value  $R_a$ . However, the high roughness peaks can not be removed by erosive process alone.
- (3) In the later polishing stage, the effectiveness of three-body-loose-abrasive process in removing high roughness peaks was demonstrated. It can be inferred to a larger extent that the three-body-loose-abrasive process under normal polishing condition with polishing load are responsible for the improvement of ball roundness value.
- (4) The best polishing results were achieved when the upper plate lapping area was in “mirror-shining” condition. Experimental results show that in order to achieve desired surface roughness value, the initial surface quality of the upper plate should be reasonably high.
- (5) The deep scratches left on the ball surface by diamond particle ploughing during the previous lapping process could be difficult to remove during the polishing process. This suggests that in order to obtain better surface quality, the diamond particle size should be reduced gradually in previous lapping process, to avoid leaving any deep scratches on the ball surface.
- (6) The best polishing results so far achieved for the polished Type 2 balls are a ball roundness of 0.08~0.09  $\mu\text{m}$  which is above the grade 5 and close to the grade 3 specification for precision bearing balls, and a surface roughness  $R_a$  value of 0.003 $\mu\text{m}$ , and a rms ( $R_q$ ) value of 0.004  $\mu\text{m}$  which is above the grade 3 specification for precision bearing balls. It proves this novel eccentric lapping machine is suitable for polishing advanced ceramic balls as well.

## REFERENCES

- [1] R. T. Cundill, *High-precision silicon nitride balls for bearings*, vol. 1573. Bellingham, WA, USA: Int Soc for Optical Engineering, 1992.
- [2] I. D. Marinescu, H. K. Tönshoff, and I. Inasaki, *Handbook of ceramics grinding and polishing: properties, processes, technology, tools and typology*. Westwood, N.J.: Noyes Publications, 1998.

- [3] N. Umehara and K. Kato, "Magnetic fluid grinding of advanced ceramic balls," *Wear*, vol. 200, pp. 148-153, 1996.
- [4] M. Jiang and R. Komanduri, "On the finishing of Si<sub>3</sub>N<sub>4</sub> balls for bearing applications," *Wear*, vol. 215, pp. 267-278, 1998.
- [5] T. H. C. Childs, S. Mahmood, and H. J. Yoon, "The Material Removal Mechanism in Magnetic Fluid Grinding of Ceramic Ball-Bearings," *Proceedings of the Institution of Mechanical Engineers Part B-Journal of Engineering Manufacture*, vol. 208, pp. 47-59, 1994.
- [6] F. Y. Chang and T. H. C. Childs, "Non-magnetic fluid grinding," *Wear*, vol. 223, pp. 7-12, 1998.
- [7] C. J. Evans, E. Paul, D. Dornfeld, D. A. Lucca, G. Byrne, M. Tricard, F. Klocke, O. Dambon, and B. A. Mullany, "Material removal mechanisms in lapping and polishing," *CIRP Annals-Manufacturing Technology*, vol. 52, pp. 611-633, 2003.
- [8] J. Kang and M. Hadfield, "A novel eccentric lapping machine for finishing advanced ceramic balls," *Journal of Engineering Manufacture, Proceedings of Institution of Mechanical Engineer, Part B*, vol. 215, pp. 781-795, 2001.
- [9] J. Kang and M. Hadfield, "Parameter optimization by Taguchi Methods for finishing advanced ceramic balls using a novel eccentric lapping machine," *Journal of Engineering Manufacture, Proceedings of Institution of Mechanical Engineer, Part B*, vol. 215, pp. 69-78, 2001.
- [10] W. Y. Fowlkes and C. M. Creveling, *Engineering methods for robust product design, Using Taguchi Methods in technology and product development*: Addison-Wesley Publishing Company, 1995.
- [11] I. M. Hutchings, *Tribology: Friction and Wear of Engineering Materials*. London: Arnold, 1992.

## List of Tables and Figures

### *List of Tables*

- Table 1** Summary of polishing materials
- Table 2** Some characteristics of HIPed silicon nitride balls being polished
- Table 3** Standard L4 Orthogonal Array used in Taguchi Methods
- Table 4** Chosen parameters and their levels for polishing test
- Table 5** Polishing test results
- Table 6** Level average response analysis in terms of surface roughness value  $R_a$  and in terms of signal-to-noise ration  $S/N_{STB}$

### *List of Figures*

- Fig. 1** Overview of the novel eccentric lapping machine system
- Fig. 2** Principle of eccentric lapping
- Fig. 3** Gap Polishing
- Fig 4** Surface topography comparison of Type 1 balls gap polished (a),  
with normal polished (b)
- Fig 5** Surface topography comparison of Type 2 balls gap polished (a),  
with normal polished (b)
- Fig. 6** Condition of upper plate lapping area
- Fig. 7** Roundness measurement of Type 2 balls before polishing
- Fig. 8** Roundness measurement of Type 2 balls after polishing
- Fig. 9** Two surface topography measurements of Type 2 balls after polishing

---

Lapping plates	material: EN1A mild steel upper plate flat, lower plate with eccentric V-groove V-groove angle 90° symmetric axis parallel to rotating axis diameter of circular V-groove 65 mm eccentricity (distance between centre of circular V-groove and rotating axis) 8 mm
Diamond Paste	Metadi II diamond paste, ¼ µ, 1µ
Lubricating Fluid	Metadi fluid (water based) 40-6064UK

---

Table 1 Summary of polishing materials

	Type 1 (Ball Blank from manufacturer A)	Type 2 (Ball Blank from manufacturer B)
Manufacturing Process	Directly HIPed, then rough-ground by manufacturer	Sinter + HIPed Eccentric lapped in-house
Density (kg/m <sup>3</sup> )	3160	3237
Ball Diameter (mm)	13.255	13.06
Ball Roundness Variation in diameter (µm)	1	0.21
Surface Roughness R <sub>a</sub> (µm)	0.202	0.071
Surface Hardness (Vickers Hardness Number, VH10)	1682	1532

Table 2 Some characteristics of HIPed silicon nitride balls being polished

Run	A	B	C
1	1	1	1
2	1	2	2
3	2	1	2
4	2	2	1

Table 3 Standard L4 Orthogonal Array used in Taguchi Methods

Level	Parameters		
	A: Polishing Speed	B: Polishing Load	C: Diamond Particle Size
1	20.83 rpm	4.58 N/ball (0.47 kgf/ball)	0.25 $\mu\text{m}$
2	93.75 rpm	8.82 N/ball (0.9 kgf/ball)	1 $\mu\text{m}$

Table 4 Chosen parameters and their levels for polishing test

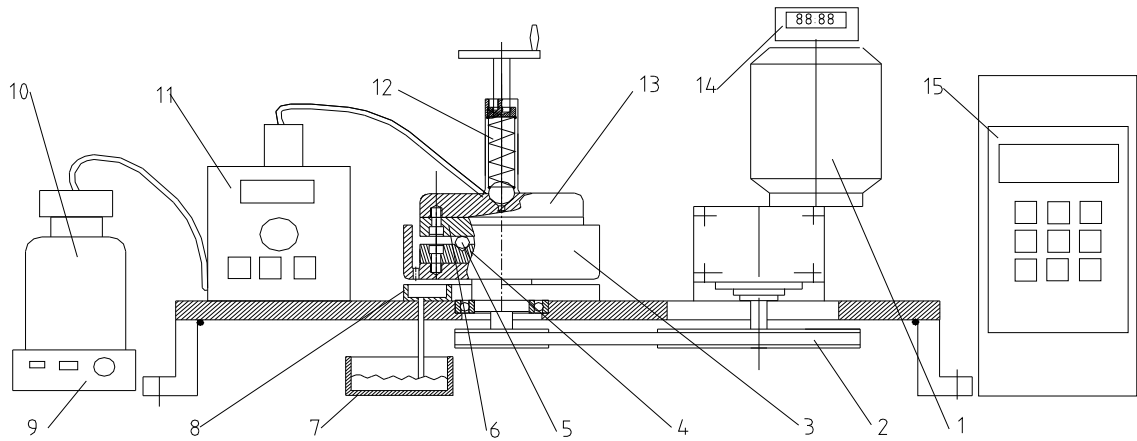


Test Run	Measured $R_a$ values from 10 samples ( $\mu\text{m}$ )										Average $R_a$ ( $\mu\text{m}$ )	STDEVP ( $\mu\text{m}$ )	$S/N_{\text{STB}}$ (dB)
1	0.0481	0.0569	0.0349	0.0506	0.0470	0.0530	0.0514	0.0458	0.0500	0.0469	0.0485	0.0055	26.24
2	0.0322	0.0298	0.0347	0.0283	0.0326	0.0337	0.0252	0.0247	0.0321	0.0263	0.0300	0.0035	30.41
3	0.0379	0.0437	0.0422	0.0444	0.0428	0.0437	0.0375	0.0429	0.0472	0.0414	0.0424	0.0028	27.44
4	0.0304	0.0316	0.0318	0.0318	0.0267	0.0240	0.0344	0.0295	0.0317	0.0300	0.0302	0.0028	30.37

Table 5 Polishing test results.

Parameter	Level	Test Run	Average of each test run $R_a$ ( $\mu\text{m}$ )	Level Average Response of $R_a$ Value ( $\mu\text{m}$ )	$S/N_{\text{STB}}$ of each test run (dB)	Level Average $S/N_{\text{STB}}$ (dB)
A. Polishing Speed	Level 1, 20.83 rpm	1	0.0485	0.0392	26.24	28.32
		2	0.0300		30.41	
	Level 2, 93.75 rpm	3	0.0424	0.0363	27.44	28.90
		4	0.0302		30.37	
B. Polishing Load	Level 1, 4.58 N/ball	1	0.0485	0.0454	26.24	26.84
		3	0.0424		27.44	
	Level 2, 8.82 N/ball	2	0.0300	0.0301	30.41	30.39
		4	0.0302		30.37	
C. Diamond Particle Size	Level 1, 0.25 $\mu\text{m}$	1	0.0485	0.0393	26.24	28.30
		4	0.0302		30.37	
	Level 2, 1 $\mu\text{m}$	2	0.0300	0.0362	30.41	28.93
		3	0.0424		27.44	

Table 6 Level average response analysis in terms of surface roughness value  $R_a$  and in terms of signal-to-noise ration  $S/N_{\text{STB}}$



- 1 AC motor and gearbox combination 2 Pulleys and belt 3 Flange shaft  
 4 Lower plate 5 Ceramic ball 6 Upper plate 7 Lapping fluid collection tank  
 8 Lapping fluid tray 9 Magnetic stirrer 10 Lapping fluid container 11 Pump  
 12 Spring-loading Unit 13 Backing plate 14 Time counter 15 MicroMaster inverter

Fig. 1 Overview of the novel eccentric lapping machine system

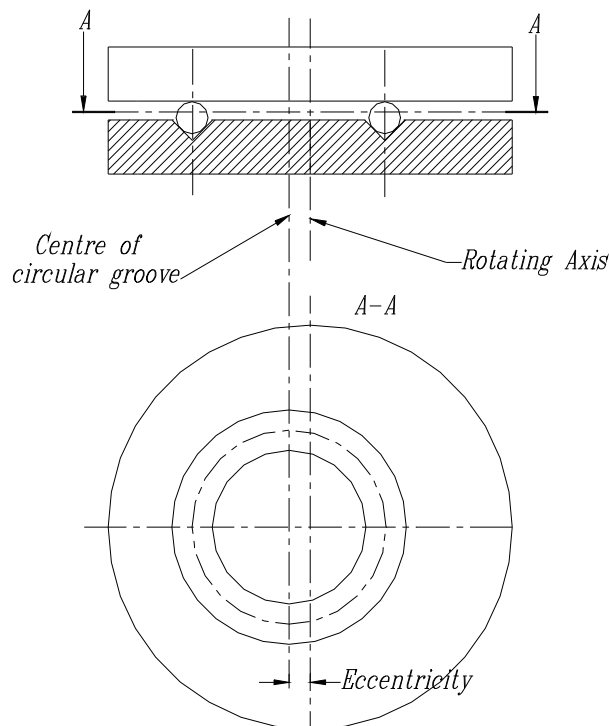


Fig 2 Principle of eccentric lapping

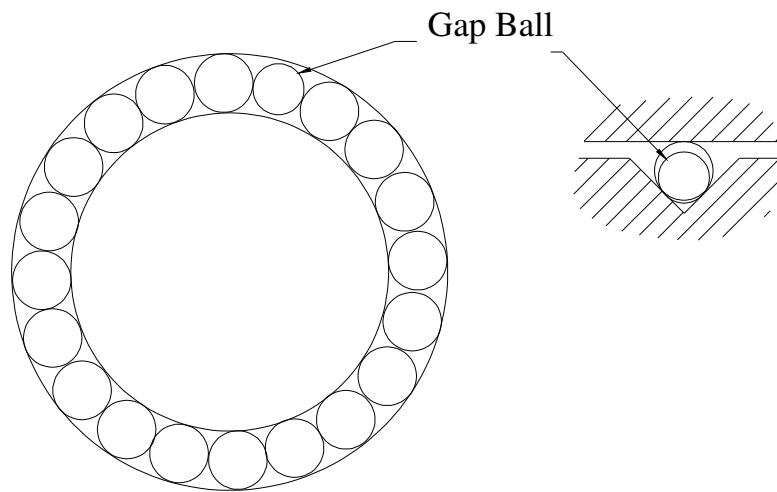
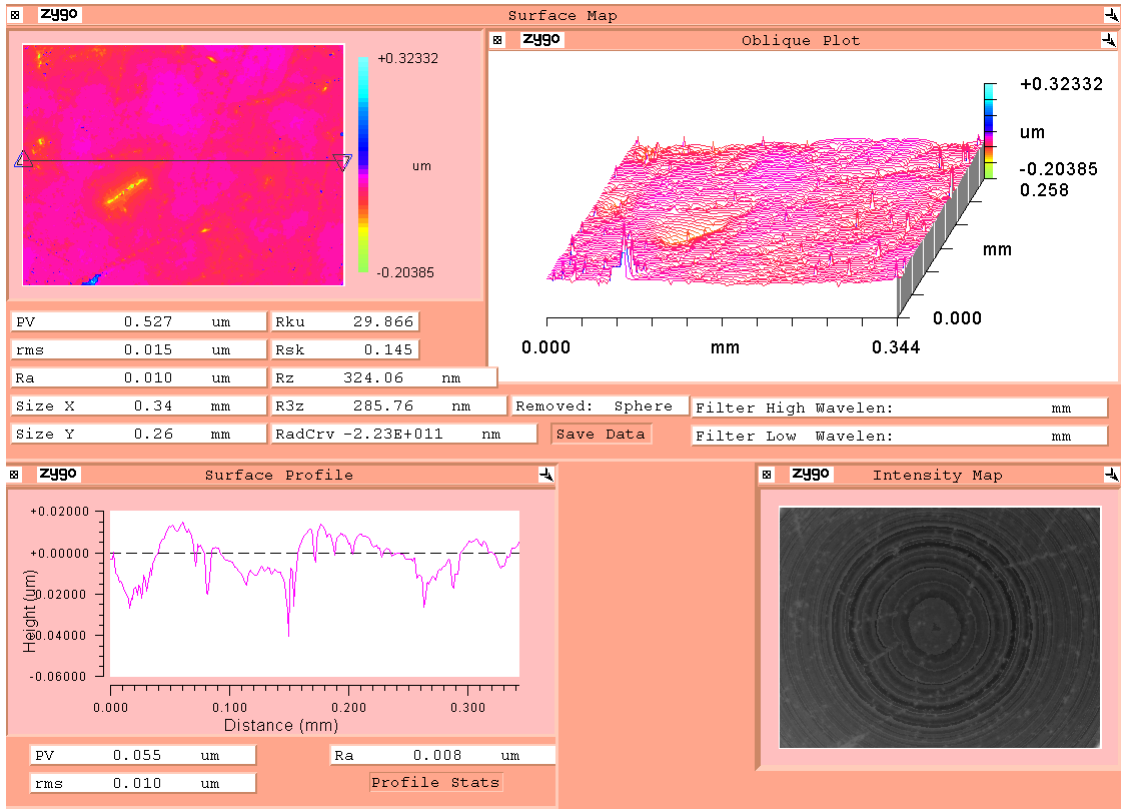
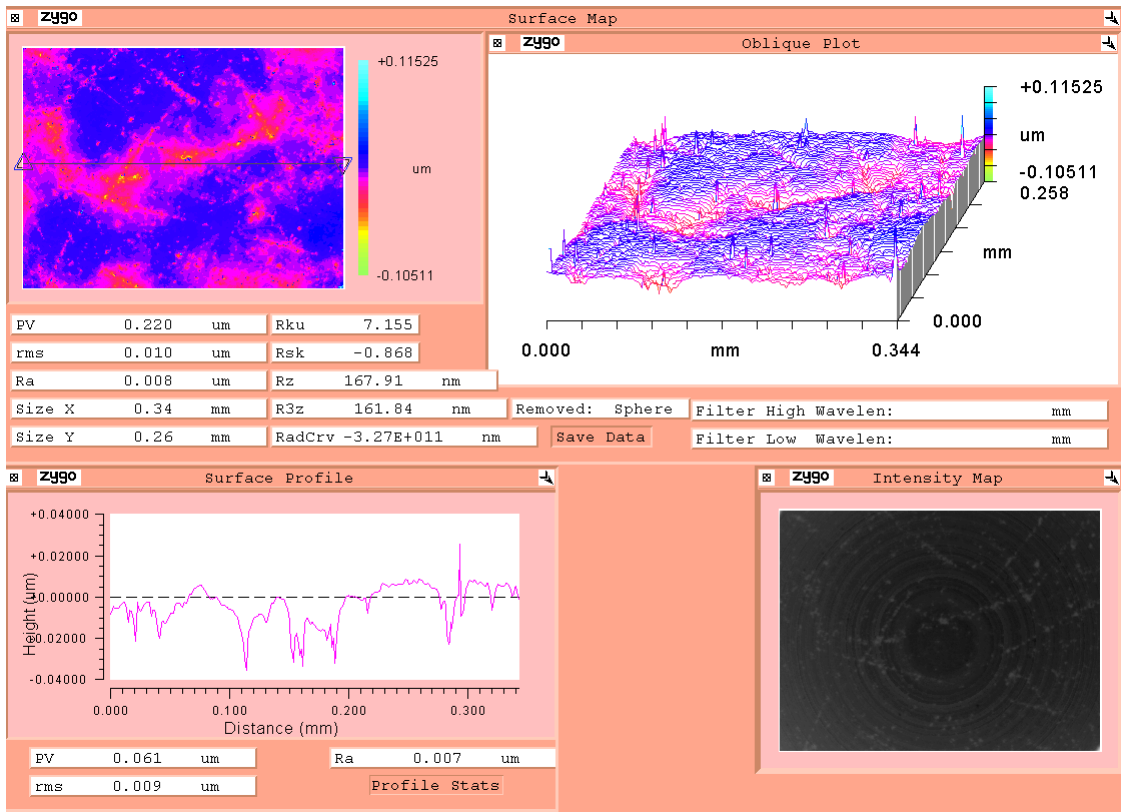


Fig 3 Gap Polishing

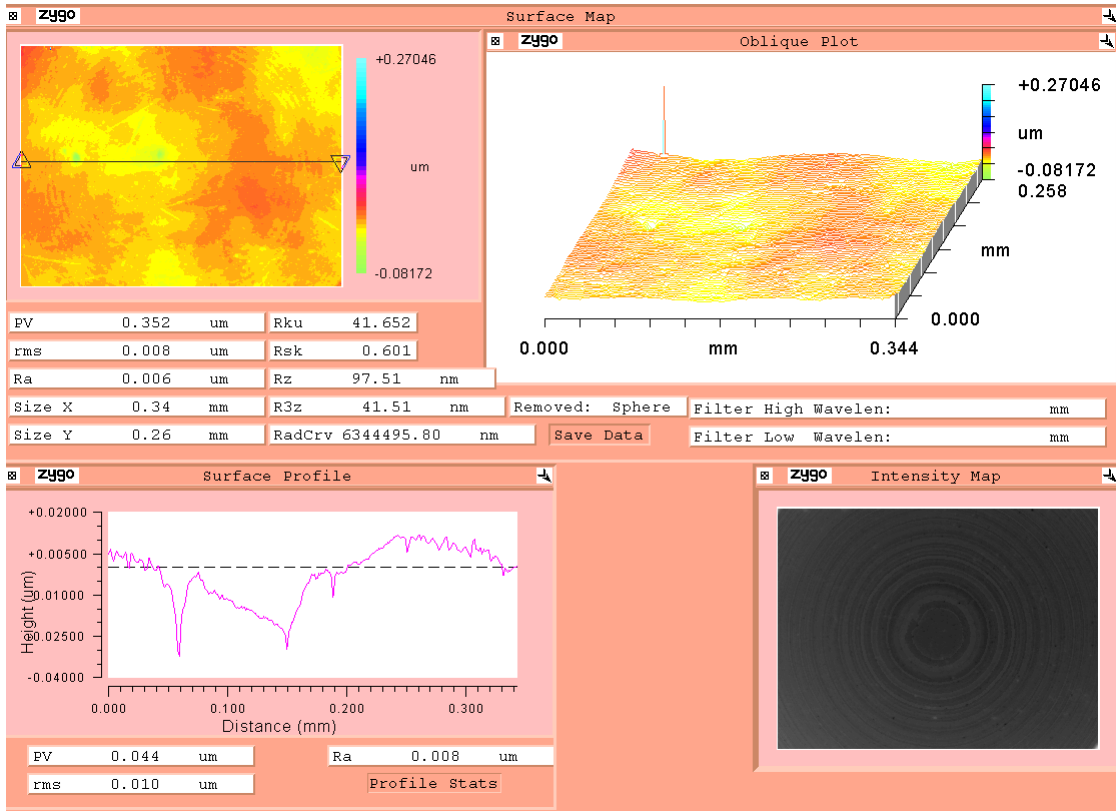


(a)

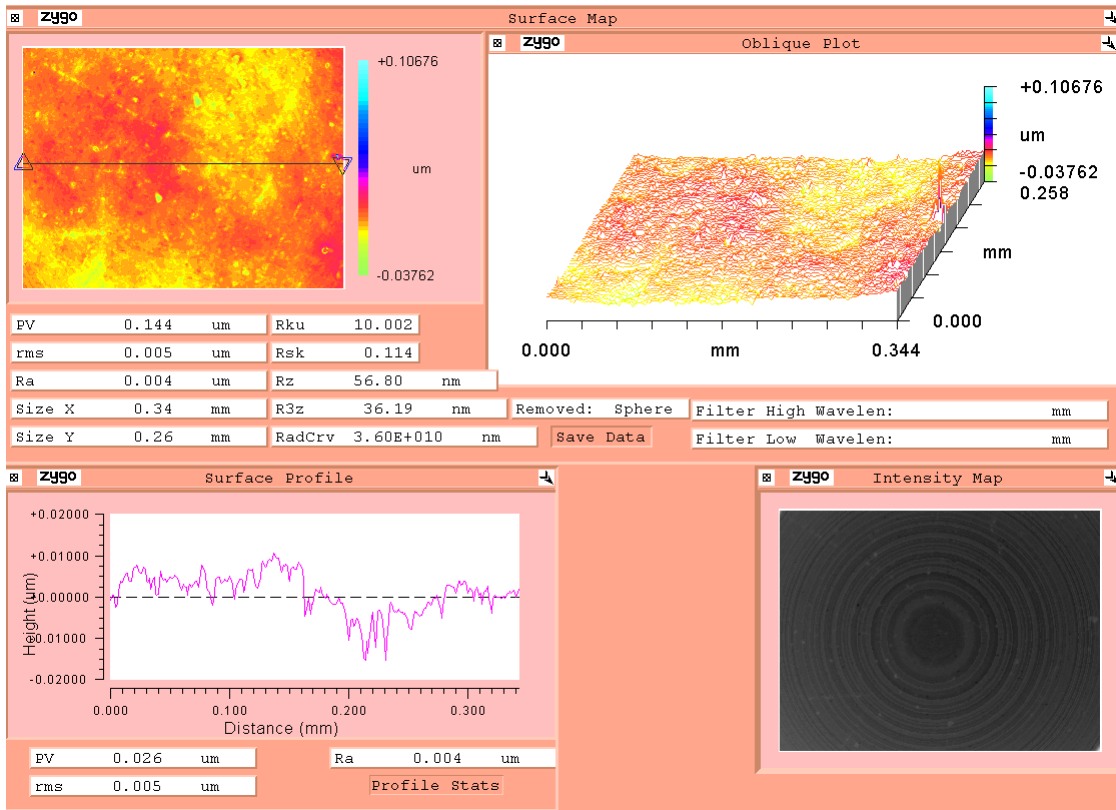


(b)

**Fig 4** Surface topography comparison of Type 1 balls gap polished (a), with normal polished

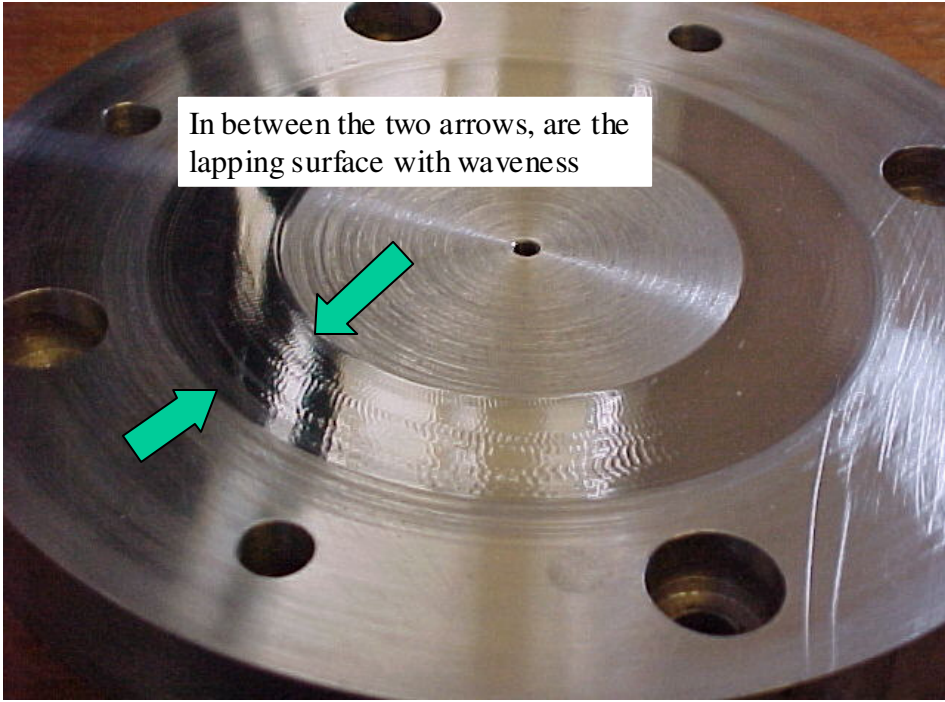


(a)



(b)

**Fig 5** Surface topography comparison of Type 2 balls gap polished (a), with normal polished (b)

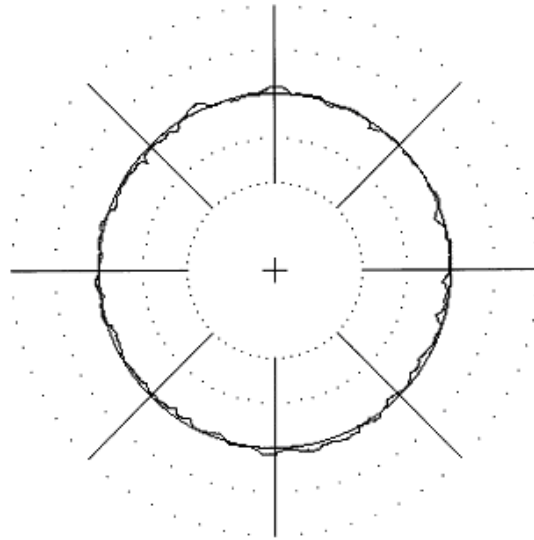


**Fig. 6** Condition of upper plate lapping area

UNFILTERED POLAR DIAGRAM

Note:  
MS02

0.5  $\mu\text{m}$  / Unit (20000)



Change MS with +/-  
Screen - Configuration  
Measuring range

LSC

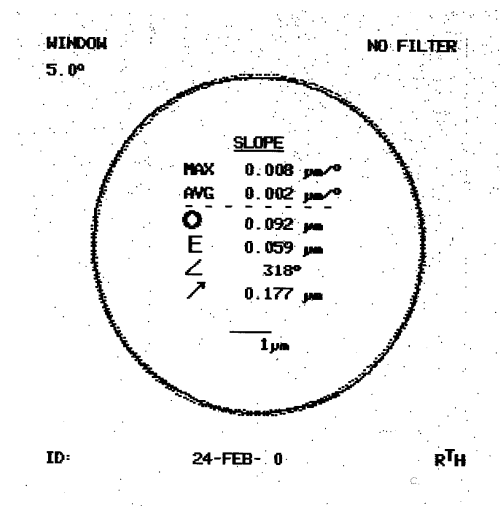
$\Delta r$  = 0.2091  $\mu\text{m}$   
 $X_m$  = -0.1160  $\mu\text{m}$   
 $Y_m$  = -0.3915  $\mu\text{m}$

MDw

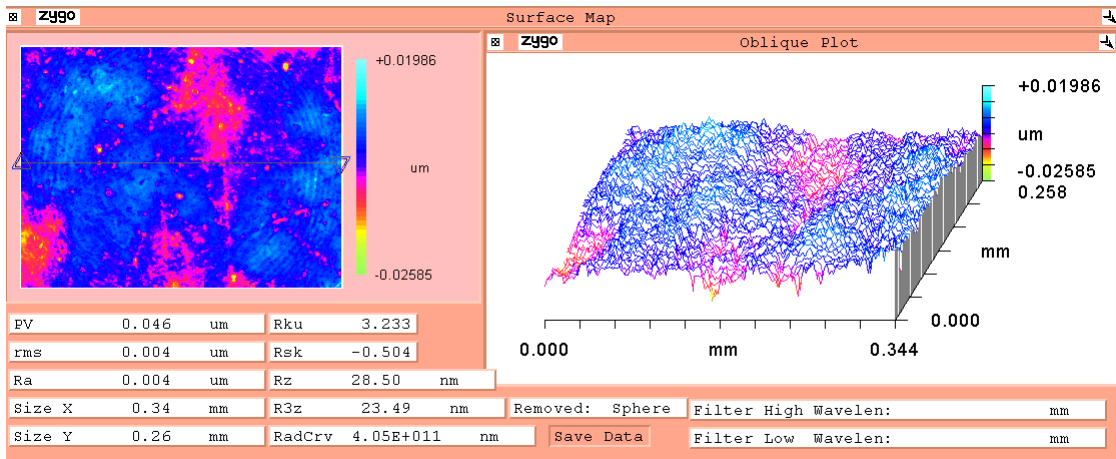
L = 6.6029  $\mu\text{m/s}$   
M = 23.0797  $\mu\text{m/s}$   
M1 = 2.9812  $\mu\text{m/s}$   
M2 = 22.8864  $\mu\text{m/s}$   
H = 57.9156  $\mu\text{m/s}$   
max1 = 11.5574  $\mu\text{m/s}$   
max2 = 11.2875  $\mu\text{m/s}$

Fig. 7 Roundness measurement of Type 2 balls before polishing

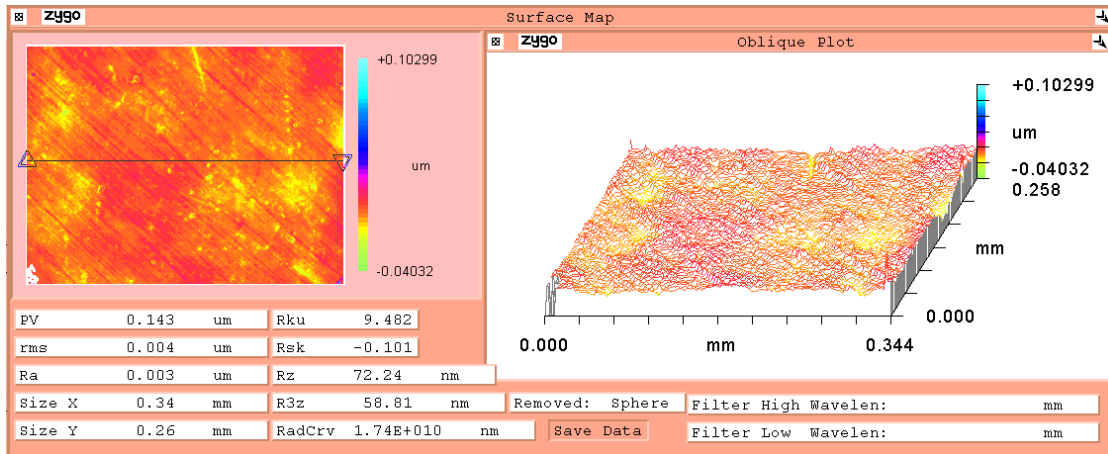




**Fig. 8** Roundness measurement of Type 2 balls after polishing



(a)



(b)

**Fig. 9** Two surface topography measurements of Type 2 balls after polishing